

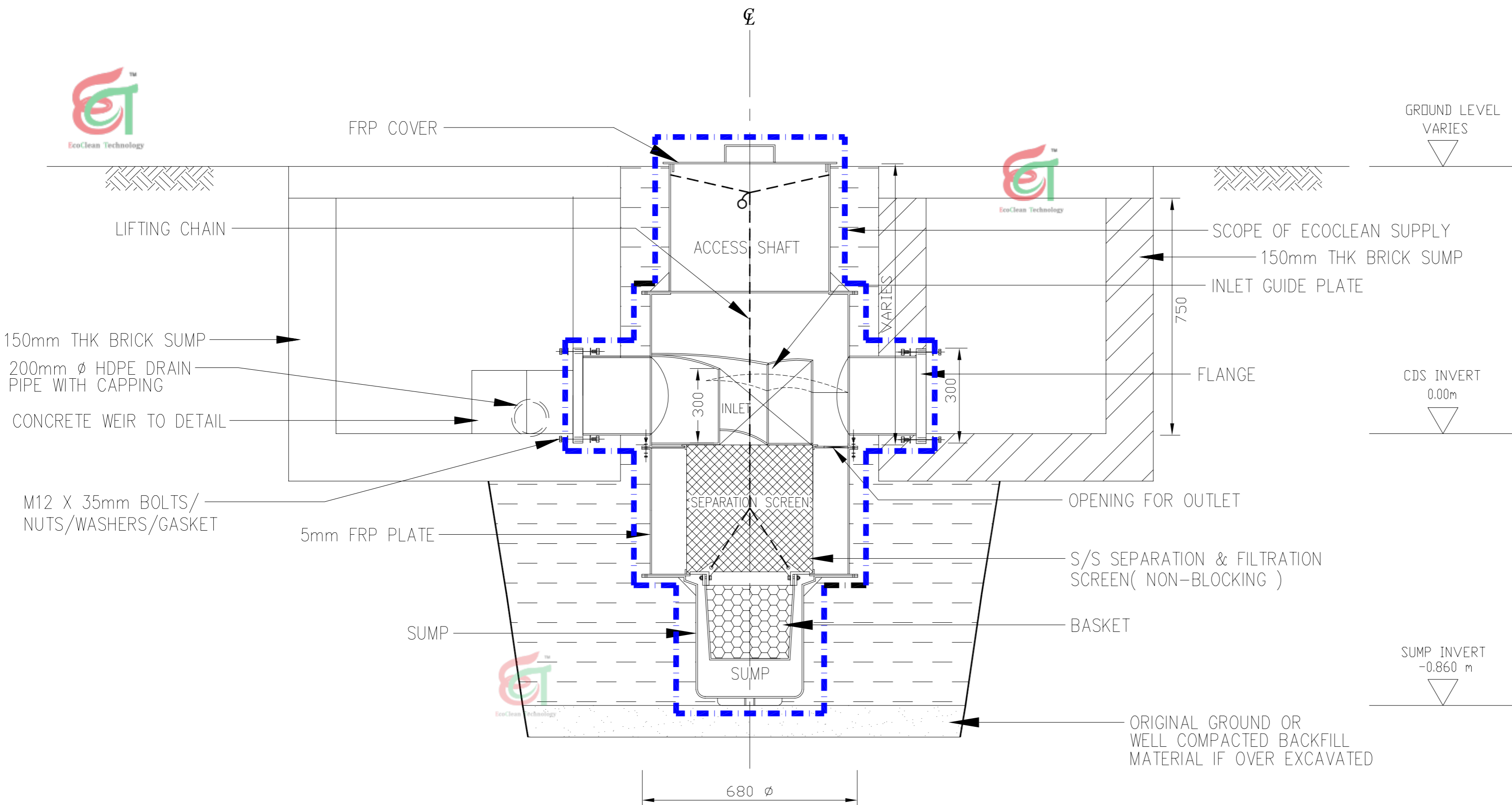

AUSTRALIAN AND INTERNATIONAL PATENTS REGISTERED ROCLA PROPRIETARY LIMITED - A.C.N. 31 000 032 191  
 CONFIDENTIAL  
 THE DESIGN DRAWINGS AND ALL INFORMATION AND CONCEPTS SPECIFIED THEREIN ARE CONFIDENTIAL AND MAY BE USED ONLY FOR THE PROJECT DESIGNATED BY CDS. CDS POLICY IS TO PROTECT ITS TECHNOLOGY AND CONFIDENTIAL INFORMATION. CDS WILL TAKE APPROPRIATE LEGAL ACTION WHERE UNAUTHORISED OR IMPROPER USE OR DISCLOSURE HAS BEEN MADE OF ITS CONFIDENTIAL INFORMATION. ALL DESIGN DRAWINGS AND OTHER CONFIDENTIAL INFORMATION ARE TO BE DESTROYED OR RETURNED TO CDS UPON COMPLETION OF THE DESIGNATED PROJECT, UNLESS REQUIRED FOR ESSENTIAL RECORD KEEPING.

COPYRIGHT  
 ©ROCLA PROPRIETARY LIMITED - A.C.N. 31 000 032 191  
 THE UNAUTHORISED USE OR REPRODUCTION OF THE DESIGN DRAWINGS IS A BREACH OF THE COPYRIGHT ACT.  
 BREACHES OF THE COPYRIGHT ACT WILL BE PROSECUTED.



SECTION A-A

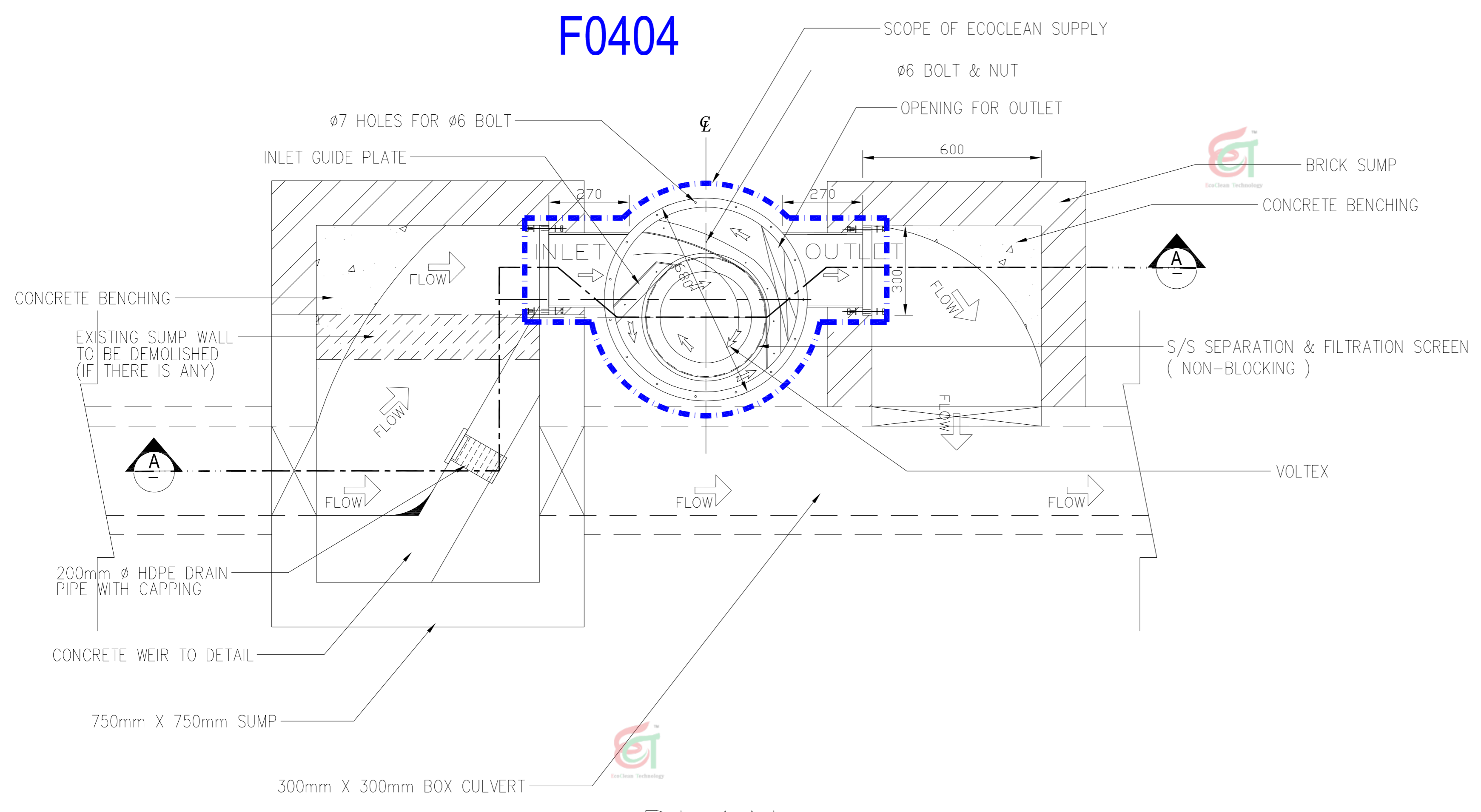

PLAN

**STANDARD DRAWING**

SUBJECT	
---------	--

DRG NO.	REFERENCE DRAWINGS

REV	DATE	DESCRIPTION	CH	AP

UNLESS OTHERWISE SPECIFIED, ALL DIMENSIONS ARE IN MILLIMETRE  
 DO NOT SCALE DRAWING, USE WRITTEN DIMENSIONS ONLY

**FOR TENDER ONLY**

**NOTES :**  
 THE DIMENSIONS OF ACTUAL PRECAST COMPONENTS MAY BE DIFFERENT FROM THE DRAWINGS, CONTRACTORS MUST CONDUCT MEASUREMENT ON SITE PRIOR TO EXCAVATION AND SHALL NOTIFY ECOCLEAN TECHNOLOGY SDN. BHD. OF ANY DISCREPANCIES FOUND. ECOCLEAN TECHNOLOGY SDN. BHD. SHALL NOT BE LIABLE OF ANY COST INCURRED AS A RESULT OF SUCH DISCREPANCIES.

**OWNER:**

**CONSULTING ENGINEER:**

**CONTRACTOR:**

**MALAYSIAN LICENSEE:**  
  
**ECOCLEAN TECHNOLOGY SDN. BHD.**  
 12A-18, WISMA ZELAN,  
 JALAN TASIK PERMAISURI 2,  
 BANDAR TUN RAZAK, CHERAS,  
 56000 KUALA LUMPUR  
 TEL: 603 - 9171 8160  
 FAX: 603 - 9171 9160  
 E-MAIL: sales@ecoclean.com.my

**PATENT RIGHT HOLDER:**  
  
**ROCLA Pty. Ltd.**  
 ABN 31 000 032 191  
 72, ORCHARDLIEGH,  
 ST. GUILDFORD, NSW 2161  
 Tel : (07)-4042 3400  
 Fax : (07)- 4042 3401

**PROJECT:**

TITLE	CDS UNIT PLAN AND SECTIONS - F0404 (DC, BASKET)
-------	---

Project	
Unit In :	mm SCALE : 1:60
Job No :	
Dwg No :	ECT/STD/F0404/SEC/01 REV 0

