

SECTION A-A

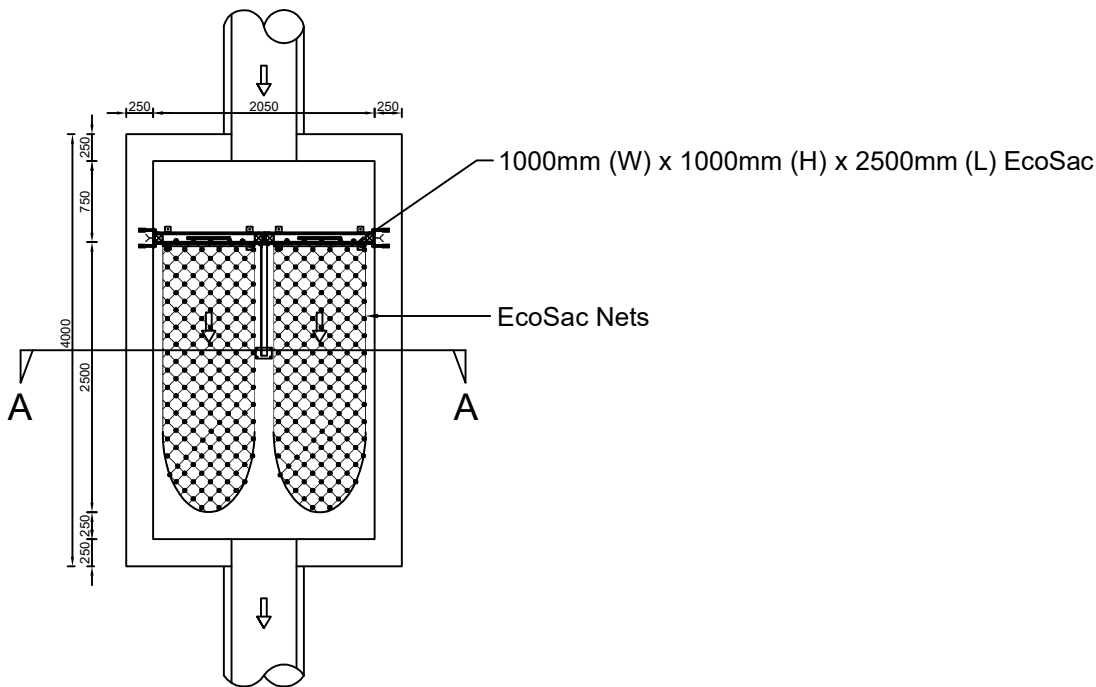

PLAN

STANDARD DRAWING

COPYRIGHT PROTECTED. ALL RIGHT RESERVED
 No part of this drawing may be reproduced, stored in a retrieval system or
 transmitted in any form or by any other means, electronic, mechanical, photocopy,
 recording or otherwise without prior permission from the Engineer.

AMENDMENTS

REV	DATE	DESCRIPTION	CHK	AP

REFERENCE DRAWINGS

UNLESS OTHERWISE SPECIFIED, ALL DIMENSIONS ARE
 IN MILLIMETRE
 DO NOT SCALE DRAWING, USE WRITTEN DIMENSIONS
 ONLY

FOR TENDER ONLY

NOTES :

THE DIMENSIONS OF ACTUAL PRECAST COMPONENTS MAY BE DIFFERENT FROM THE DRAWINGS, CONTRACTORS MUST CONDUCT MEASUREMENT ON SITE PRIOR EXCAVATION AND SHALL NOTIFY ECOCLEAN TECHNOLOGY SDN. BHD. OF ANY DISCREPANCIES FOUND. ECOCLEAN TECHNOLOGY SDN. BHD. SHALL NOT BE LIABLE OF ANY COST INCURRED AS A RESULT OF SUCH DISCREPANCIES.

OWNER:

CONSULTING ENGINEER:

CONTRACTOR:

MALAYSIAN LICENSEE:



ECOCLEAN TECHNOLOGY SDN. BHD.

12A-18, WISMA ZELAN,
 JALAN TASIK PERMAISURI 2,
 BANDAR TUN RAZAK, CHERAS,
 56000 KUALA LUMPUR

TEL: 603 - 9171 8180
 FAX: 603 - 9171 9180
 E-MAIL: sales@ecoclean.com.my

PROJECT:

TITLE ECOSAC E1025
 2 UNITS (1.0m x 1.0m)
 PLAN AND SECTIONS

Project			
Unit In :	mm	SCALE :	1:25
Job No :			
Dwg No :	ECT/STD/E1025/SEC/01	REV	0