

Advanced Flocculation Bio-Reactor (AFBR)

AFBR PROCESS DIAGRAM

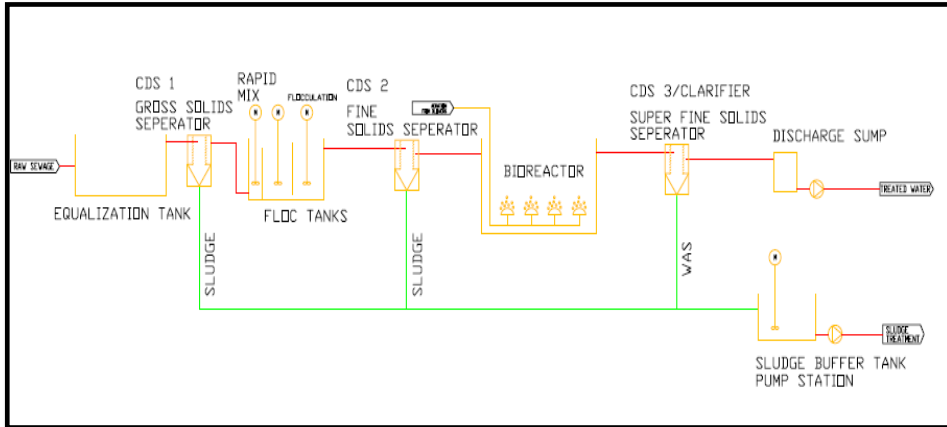

COMPLETED PILOT PROJECT, IJOK SELANGOR



Advantages of EcoClean AFBR (Advanced Flocculation Bio-Reactor) System

- Significantly lower plant cost
- Up to 30% savings in operation costs
- Less Overall Space requirement
- Lower Requirement for Electrical and Mechanical Equipment
- Lower Detention Period
- Lower Power Consumption (Approximately 70% of the Conventional)
- No Addition of Micro/Macro Nutrients
- Complete Removal of Color and Odor
- Does Not Require Force Operation on Holidays
- Low Pay Back Period due to Huge Saving on Electricity and other Consumables